



CAP Pico

Compressed
Air Pneumatics



Pneumatic devices powered by pressurized natural gas are widely used in the natural gas industry for process control and chemical injection. These devices vent methane directly into the environment threatening the clean fuel advantages of natural gas.

Qnergy's smallest air package, the CAP Pico delivers clean, oil-free instrument air utilizing solar PV.

Benefits

Emissions-free methane mitigation

Once a year maintenance

Redundant brushless DC compressors

Dual pressure output 35/100psi

Self-contained methane abatement solution with no recurring operating costs

Options

Remote monitoring of operating conditions and alarms

Expansion module for additional PV panels and battery autonomy

24VDC supplemental Power input

External desiccant dryer



	Primary	Backup
Max Air Flow	1 scfm at 35 psi	0.25 scfm at 100 psi

System Operations Specifications

	CAP Pico	CAP Pico+
Nominal Air flow at 35psi (scfm)*	0.5 (720 scfd)	1.0 (1440 scfd)
Power Consumption	100W	180W
Operating voltage	24VDC (22.5 to 31VDC)	
Communications	Modbus TCP/IP	
*PV performance depends on deployment location: nominal flow based on central Texas model		

Instrument Air Specifications

Compressor	Duplex brushless DC
Maximum Pressure (Primary / Backup)	60 psi / 115 psi
Wet Air Receiver (Primary)	20 gal
Flow Metering	5% accuracy

Control

Control	7" HMI with sun shade
---------	------------------------------

General Specifications

Area Class Rating	General Purpose
Temp Rating	5°F to 122°F (-15°C to 50°C)
Dimensions	87" x 51.2" x 84.2" 2210 x 1300 x 2139 mm
Weight	1338 lbs (607 kg)
Heating	Heated diverter manifold
Ventilation	Forced Air
Warranty	1 year

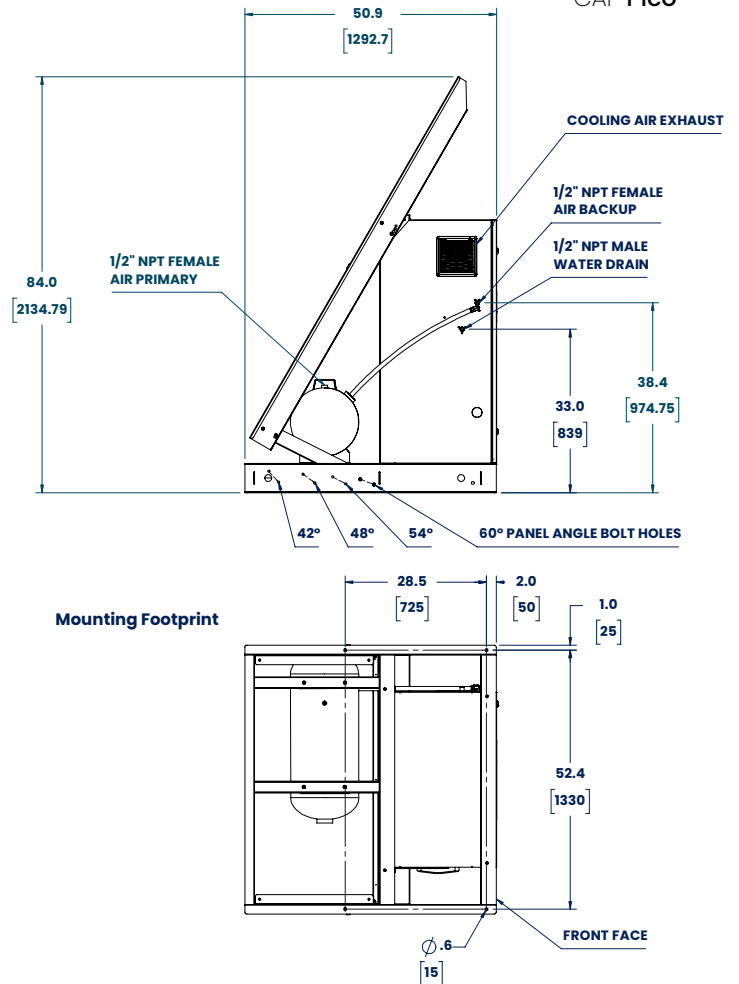

Power System Specifications

	CAP Pico	CAP Pico+
Solar PV Module Capacity	900 - 1000W	1800 - 2000W
Battery Quantity (option)	4 (6)	8 (12)
Battery Type	12V 8D 260AH Gel Monobloc	
Battery Life	>1300 cycles @ 50% DOD	