



PowerGen 5650



Remote Power Industrial Application

Qnergy's PowerGen is a thermal-powered generator suitable to meet remote power needs utilizing virtually any combustible gaseous fuel.

All Qnergy PowerGen generators feature our patented QB80 Series Stirling Engines.

The PowerGen generator provides reliable, affordable electricity to areas around the globe with little or no existing power distribution infrastructure.

PowerGen Engine Specifications

The PowerGen utilizes the Qnergy QB80 series engine. They are the most powerful Stirling machines on the market today. As an external combustion engine, the Qnergy QB80 can run on almost any heat source. The engine is designed for long, uninterrupted and quiet operation.



QB80 Engine Specifications

Engine Model	QB80
Engine Type	Stirling Engine
Engine Architecture	Free Piston (frictionless)
Service	None
Weight	242 lbs (109.7 kg)
Length	33.10 in (84 cm)
Diameter	14.45 in (36.7 cm)
Charging Gas	Inert Helium



Product Application and Engineering

General

Make	Qnergy
Model	QRP 2A-HNS
Engine	QB80
Engine Type	Stirling Engine
Engine Controller	QEC 3.5

Electrical System

System Output Power	See Configuration
Power Max Gage Wire Interface	6-20 AWG
Cable Gland Input	3/4" Std
Ignition/Standby Battery (standard)	Sealed AGM Deep Cycle, 12V DC 40 Ah
Battery Capacity (Optional: for increased standby)	Up to 160 Ah
Safety	E-stop (normally closed)

Communication

Ethernet	RJ45
Protocol	Modbus RTU
Internet Infrastructure	TCP/IP
Remote Data Viewer	Qnergy Dashboard
Discrete I/O's	Configurable
Inputs (Dry Contact)	x6 (16-20 AWG)
Outputs (Relay)	x8 (16-20 AWG) (Max 250 V / 1 A)

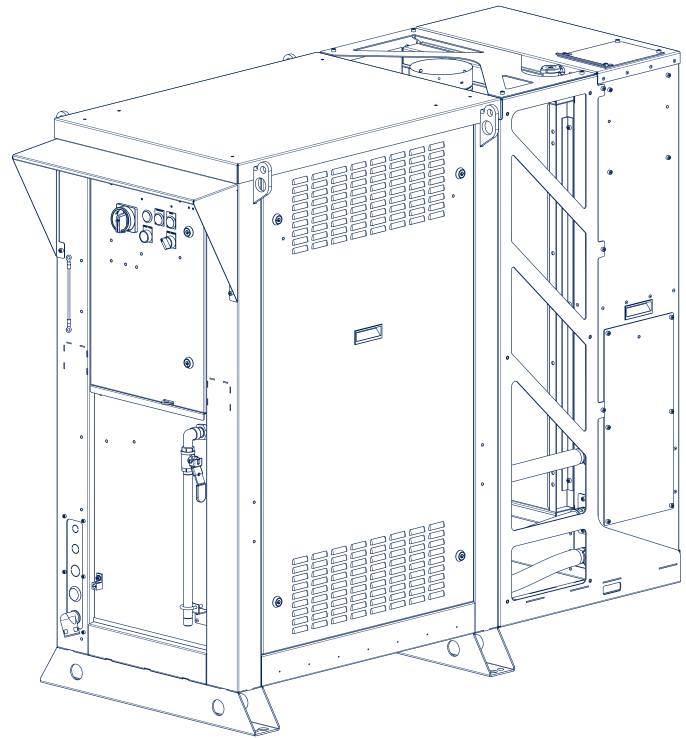

Fuel System

Fuel Type	Dry Natural Gas, Propane (C1-C4), other gaseous fuel*
Burner	Pre-mix
Ignition	Direct
Gas Regulator	2-Stage
Gas Pressure Monitor	Transducer
Fuel Port	1/2" NPT Male

*contact us regarding using any non-standard gaseous fuels (C1-C4)

Cooling System

Cooling System Type	High Efficiency Closed Loop
Cooling Fan Type	PWM Fan (qty. 2)
Max Coolant Volume	4.2 gal (16 l) (antifreeze)

Product Operational Data

SERIES	CONFIGURATION	OUTPUT	PHASE ANGLE	CONNECTION	MAX POWER (5650) @85°F 120°F
A	120V/240VAC Split Phase	Output A: 120VAC 60Hz Output B: 120VAC 60Hz	A: 0° B: 180°	3 wire: L1, L2 & Common/Neutral	5.65kW 5.1kW

OPTIONAL ELECTRICAL CONFIGURATIONS UPON REQUEST (VAC/VDC)

Low voltage DC outputs (24 VDC / 48 VDC) requires the use of the Qnergy Power Interface Package (PIP)

Fuel Operational Specifications

Fuel Consumption Natural Gas	1,433-3,964 ft³/day (40.58-112.25 m³/day)
Fuel Consumption Propane	15.2-44.4 gal/day (57-168 lt/day)
Fuel Pressure Range Natural Gas	3-50 PSI (21-345 kpa)
Fuel Pressure Range Propane	2-10 PSI (14-69 kpa)
Wobbe Index	832-2,163 BTU/ft³ (31-81MJ/m³)
Caloric Value	751-3,382 BTU/ft³ (28-126 MJ/m³)

*contact us regarding using non-standard gaseous fuels (C1-C4)

HRU Operational Specification

Thermal Heat Rejection (Max Available)	x2.5-3.5 of Electric Power Output
----------------------------------------	------------------------------------------

Environmental Condition Specifications

Sound	Max dBA	< 75 dBA @ 1 m
Ambient Temperature Continuous Operation*		-13 °F-122 °F -25 °C-50 °C
Ambient Temperature Rated (Cold Start)		5 °F-122 °F -40°F available -40 °C available
Altitude	Derate	5% derate every 1,000 ft (above 5,000 ft)

Emissions

NOx @ 5% O ₂	30.0 ppm	66 mg/kWh
CO @ 5% O ₂	9.0 ppm	12 mg/kWh
VOC	-	Negligible, Lean Combustion

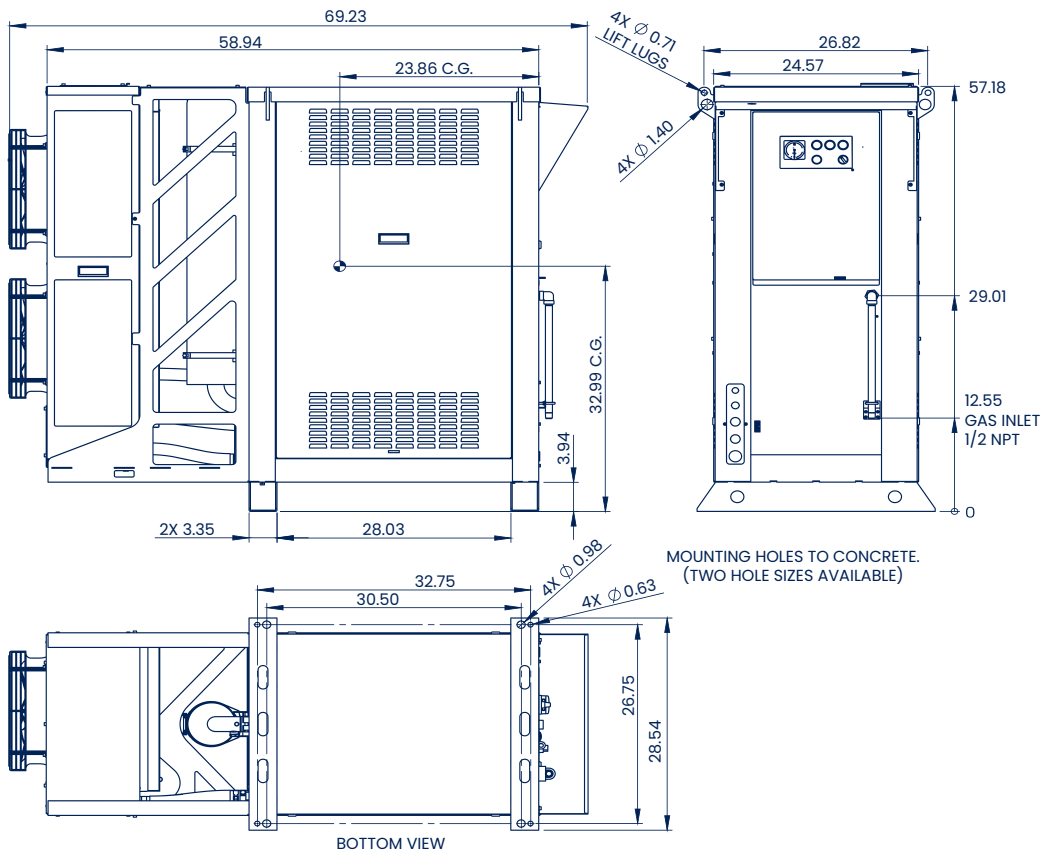

PowerGen Dimension/Weight

Dry Weight
866 lbs (392kg)

Base Crate:

Length (L)
75.25 in (752.5 mm)

Width (W)
40.25 in (402.5 mm)

Height (H)
63.8 in (638 mm)

Weight
220 lbs (99.7 kg)

HRU Standalone Dimensions

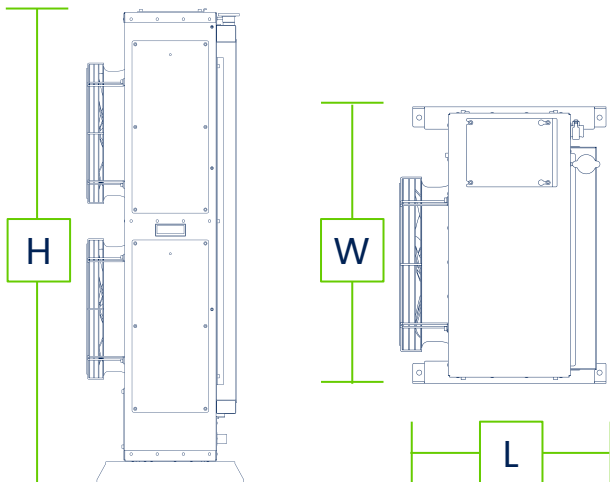

HRU Floor Standing:

Length (L)
19 in (482 mm)

Width (W)
25.4 in (645 mm)

Height (H)
54 in (1371 mm)

HRU Wall Mounted:

Length (L)
28.8 in (731 mm)

Width (W)
24.9 in (632 mm)

Height (H)
53.3 in (1353 mm)

HRU Max Placement Distance **65.5 ft (19.96 m)**